

NOTE:
F – DENOTES FACE LIFT

L1

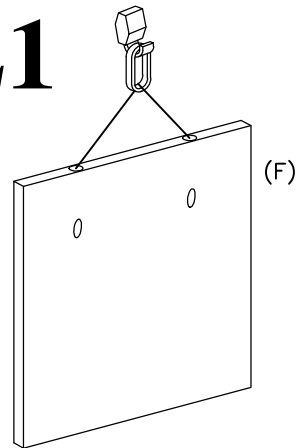

2 WAY EDGE
OR
2 WAY FACE **L1-F**

L2

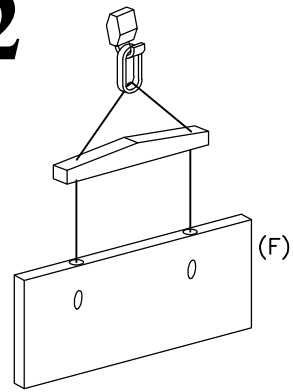

2 WAY EDGE WITH SPREADER
OR
2 WAY FACE WITH SPREADER **L2-F**

L3

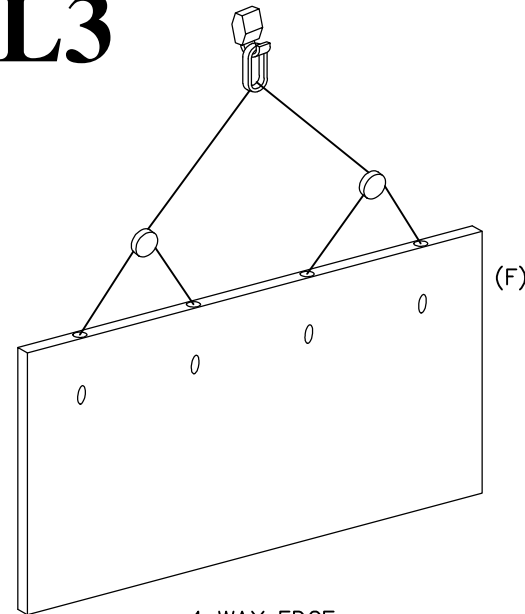

4 WAY EDGE
OR
4 WAY FACE **L3-F**

L4

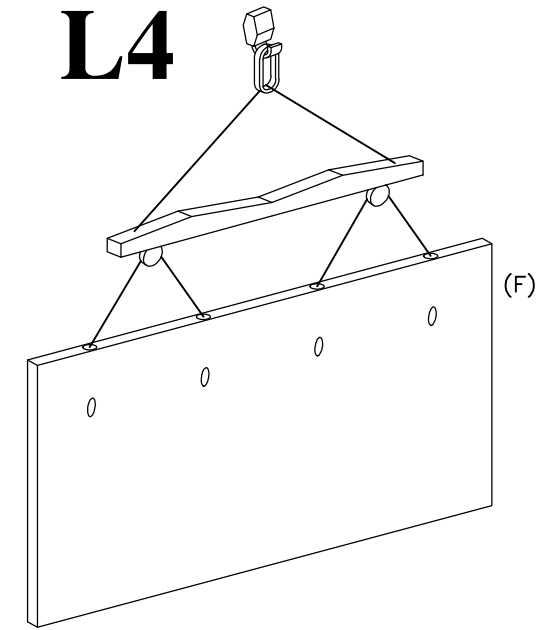

4 WAY EDGE WITH SPREADER AND TOP PULLEYS
OR
4 WAY FACE WITH SPREADER AND TOP PULLEYS **L4-F**

L5

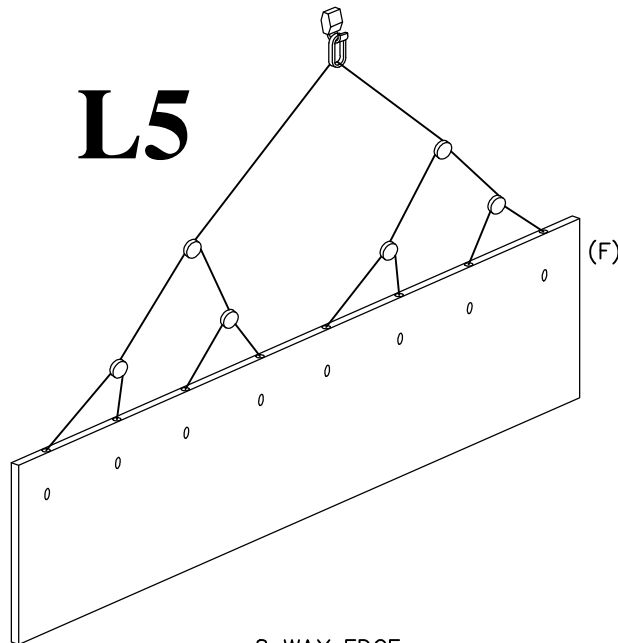

8 WAY EDGE
OR
8 WAY FACE **L5-F**

L6

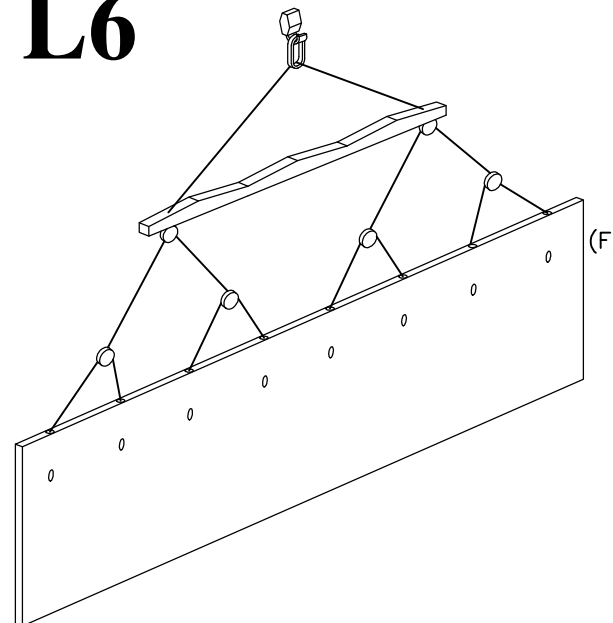

8 WAY EDGE WITH SPREADER
OR
8 WAY FACE WITH SPREADER **L6-F**

L7

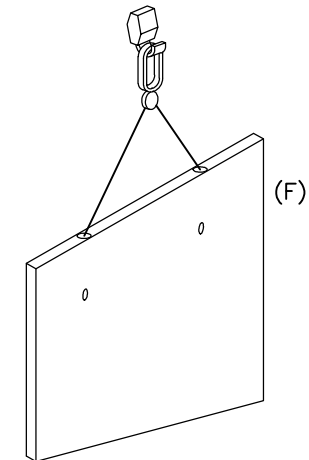

2 WAY EDGE WITH TOP PULLEY
OR
2 WAY FACE WITH TOP PULLEY **L7-F**

IF ANY CODE ON A DRAWING OR PANEL LABEL STATED AS "SPECIAL" OR "S" REFER TO THE SPECIFIC SHOP DRAWING FOR RIGGING / LIFTING ARRANGEMENT

PRECAST RIGGING CODE LOADING OPTIONS

Revision:

B

Date:

31.07.2013

THIS INFORMATION IS PROVIDED AS A GUIDE ONLY, PLEASE REFER TO:
 -ENGINEERS DRAWING DETAILS.
 -APPROVED CODE OF PRACTICE FOR THE SAFE HANDLING, TRANSPORTATION AND ERECTION OF PRECAST CONCRETE.
 -APPROVED CODE OF PRACTICE FOR LOAD-LIFTING RIGGING.
 -LOAD LIFTING DESIGNERS DIAGRAMS, i.e. RAMSET, REID, ETC.

IMPORTANT

REFER TO THE PANEL SUPPLIER'S SHOP DRAWINGS FOR THE RIGGING ARRANGEMENTS TO BE USED FOR EACH OPERATION. ENSURE ALL LIFTING CLUTCHES AND OTHER EQUIPMENT IS COMPATIBLE WITH THE DEVICES CAST INTO THE PANEL BEFORE ATTACHING. ENSURE LOADS TO BE IMPOSED ON ALL DEVICES ARE WITHIN THE MANUFACTURER'S RECOMMENDATIONS.

L8

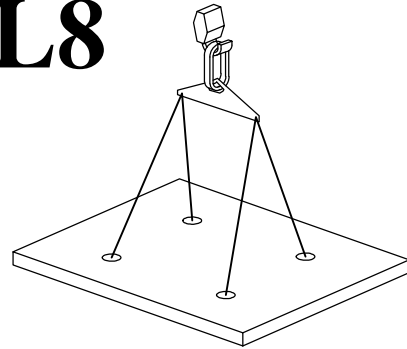

4 WAY FACE FLAT LIFT
EQUAL LOADS

L9

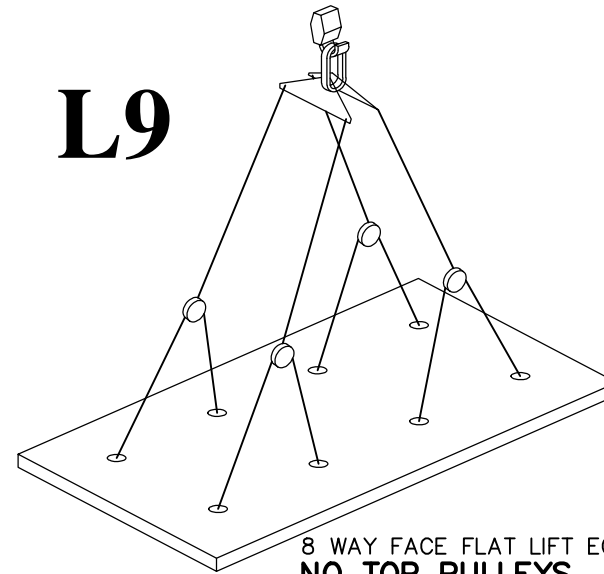

8 WAY FACE FLAT LIFT EQUAL LOADS
NO TOP PULLEYS

L10

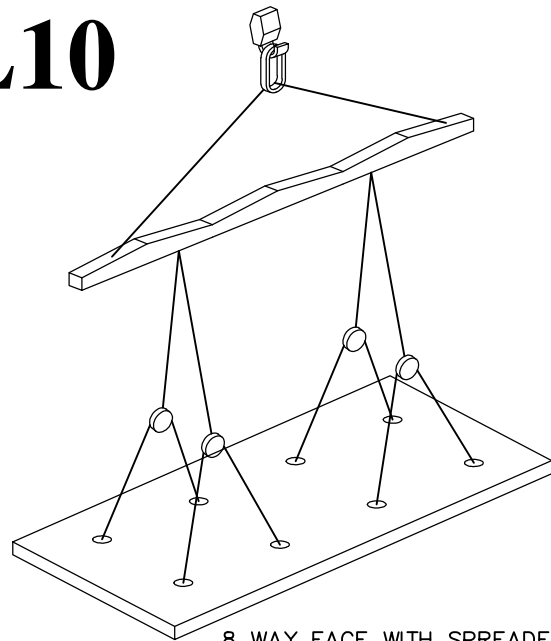

8 WAY FACE WITH SPREADER
NO TOP PULLEYS

L11

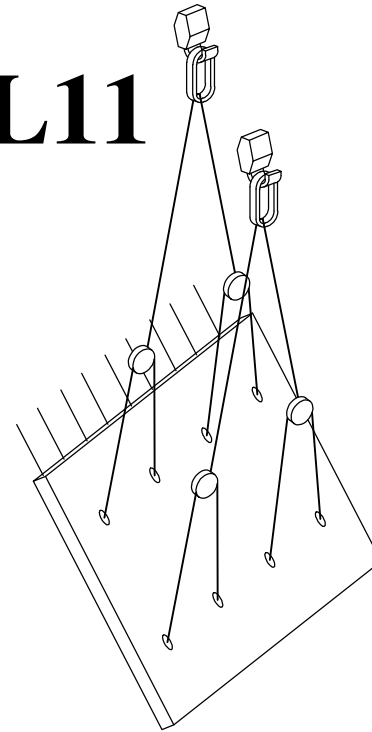

8 WAY FACE 2 HOOKS
(FOR ROTATION FROM HORIZONTAL TO VERTICAL
OR VICE VERSA)

L12

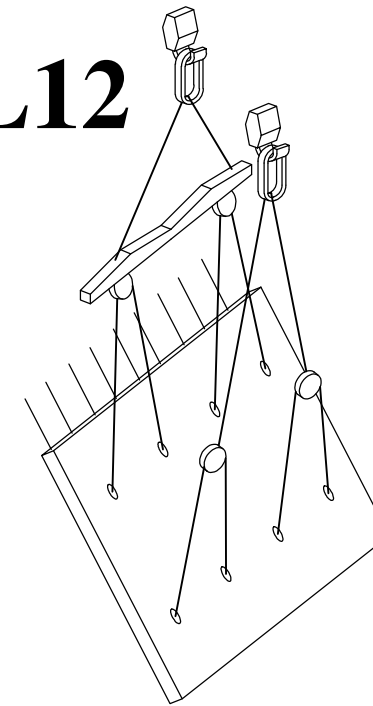

8 WAY FACE 2 HOOKS (WITH SPREADER)
(FOR ROTATION FROM HORIZONTAL TO VERTICAL
OR VICE VERSA)

IF ANY CODE ON A DRAWING OR PANEL LABEL STATED AS "SPECIAL" OR "S" REFER TO THE SPECIFIC SHOP DRAWING FOR RIGGING / LIFTING ARRANGEMENT

**PRECAST RIGGING CODE
LOADING OPTIONS**

Revision:

B

Date:

31.07.2013

THIS INFORMATION IS PROVIDED AS A GUIDE ONLY, PLEASE REFER TO:
-ENGINEERS DRAWING DETAILS.
-APPROVED CODE OF PRACTICE FOR THE SAFE HANDLING, TRANSPORTATION AND ERECTION OF PRECAST CONCRETE.
-APPROVED CODE OF PRACTICE FOR LOAD-LIFTING RIGGING.
-LOAD LIFTING DESIGNERS DIAGRAMS, i.e. RAMSET, REID, ETC.

IMPORTANT

REFER TO THE PANEL SUPPLIER'S SHOP DRAWINGS FOR THE RIGGING ARRANGEMENTS TO BE USED FOR EACH OPERATION. ENSURE ALL LIFTING CLUTCHES AND OTHER EQUIPMENT IS COMPATIBLE WITH THE DEVICES CAST INTO THE PANEL BEFORE ATTACHING. ENSURE LOADS TO BE IMPOSED ON ALL DEVICES ARE WITHIN THE MANUFACTURER'S RECOMMENDATIONS.

L13

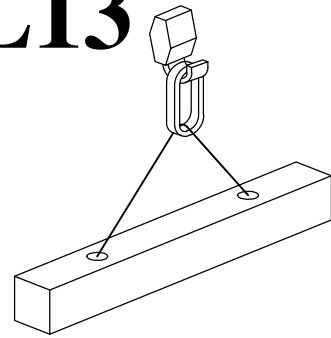

2 WAY FACE

L14

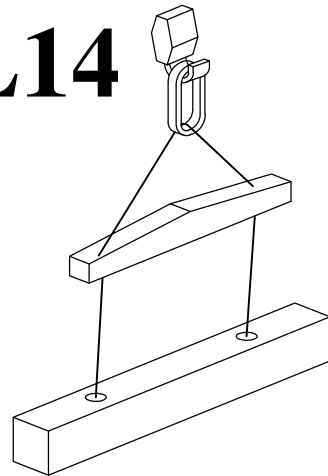

2 WAY FACE WITH SPREADER

L15

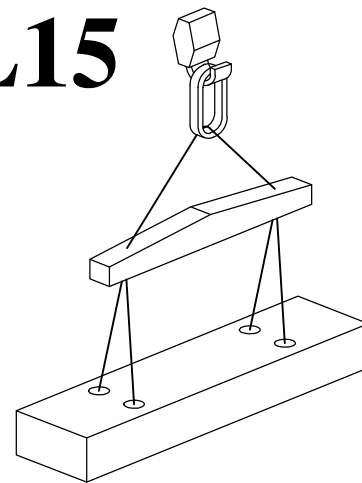

4 WAY FACE DOUBLE ROW
WITH SPREADER
NO TOP PULLEYS

L16

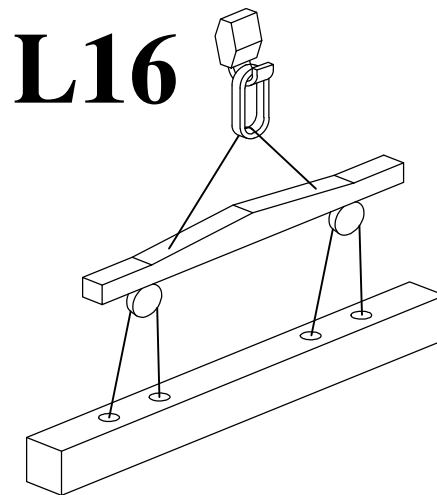

4 WAY FACE SINGLE ROW
WITH SPREADER
AND TOP PULLEYS

L17

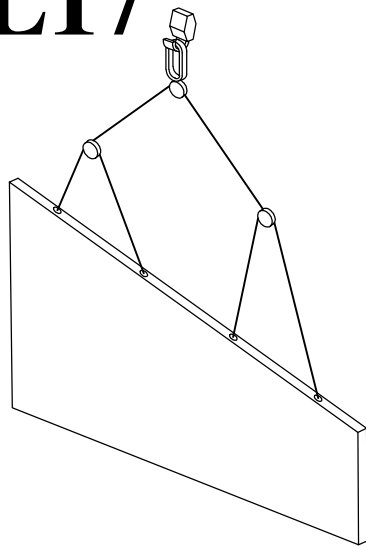

4 WAY EDGE WITH 3 PULLEYS

L18

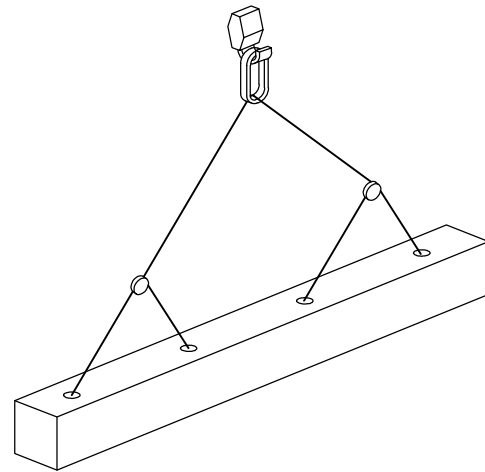

4 WAY FACE

L19

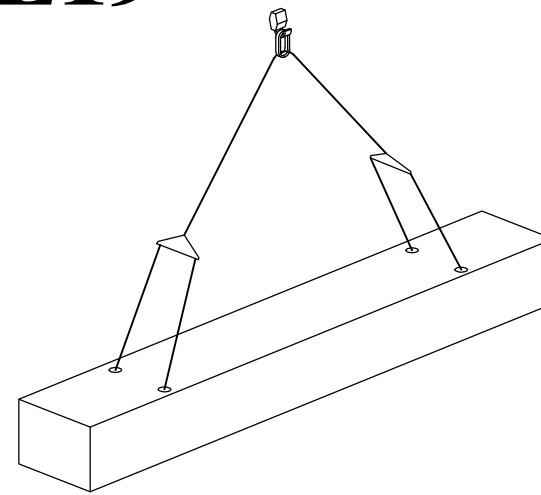

4 WAY FACE, FIXED CHAINS WITH
EQUALISING TRIANGLES

L20

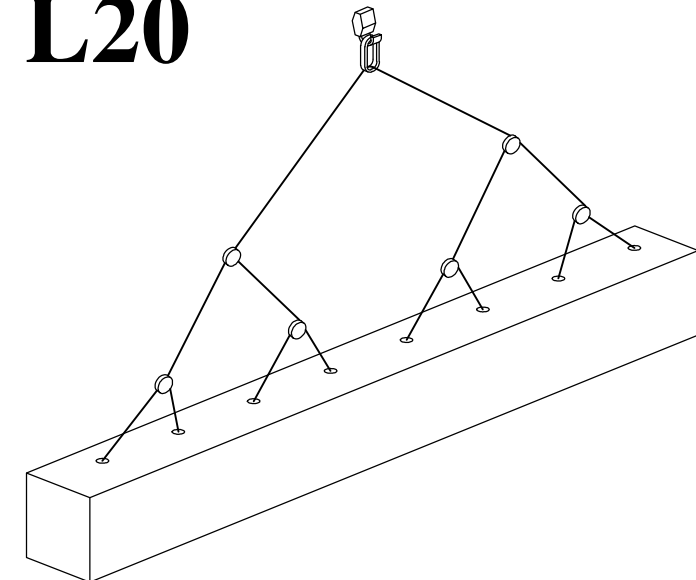

8 WAY FACE

IF ANY CODE ON A DRAWING OR PANEL LABEL STATED AS "SPECIAL" OR "S" REFER TO THE SPECIFIC SHOP DRAWING FOR RIGGING / LIFTING ARRANGEMENT



PRECAST RIGGING CODE LOADING OPTIONS

Revision:

B

Date:

31.07.2013

THIS INFORMATION IS PROVIDED AS A GUIDE ONLY, PLEASE REFER TO:
-ENGINEERS DRAWING DETAILS.
-APPROVED CODE OF PRACTICE FOR THE SAFE HANDLING, TRANSPORTATION AND ERECTION OF PRECAST CONCRETE.
-APPROVED CODE OF PRACTICE FOR LOAD-LIFTING RIGGING.
-LOAD LIFTING DESIGNERS DIAGRAMS, i.e. RAMSET, REID, ETC.

IMPORTANT

REFER TO THE PANEL SUPPLIER'S SHOP DRAWINGS FOR THE RIGGING ARRANGEMENTS TO BE USED FOR EACH OPERATION. ENSURE ALL LIFTING CLUTCHES AND OTHER EQUIPMENT IS COMPATIBLE WITH THE DEVICES CAST INTO THE PANEL BEFORE ATTACHING. ENSURE LOADS TO BE IMPOSED ON ALL DEVICES ARE WITHIN THE MANUFACTURER'S RECOMMENDATIONS.

D1

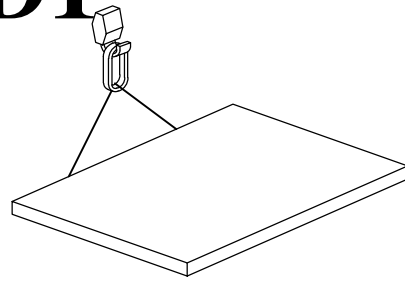

2 WAY EDGE

D2

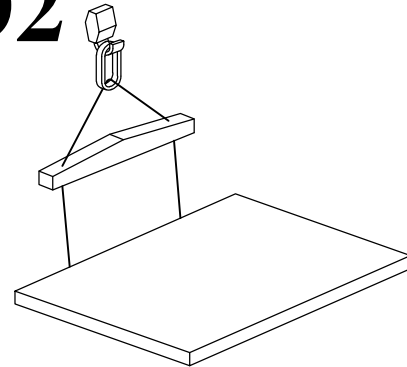

2 WAY EDGE WITH SPREADER

D3

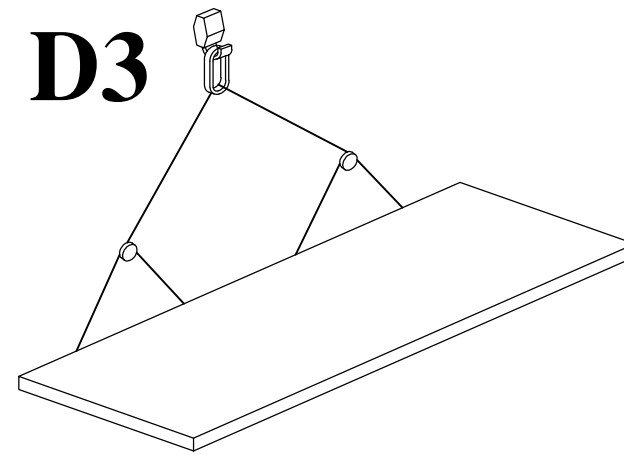

4 WAY EDGE

D4

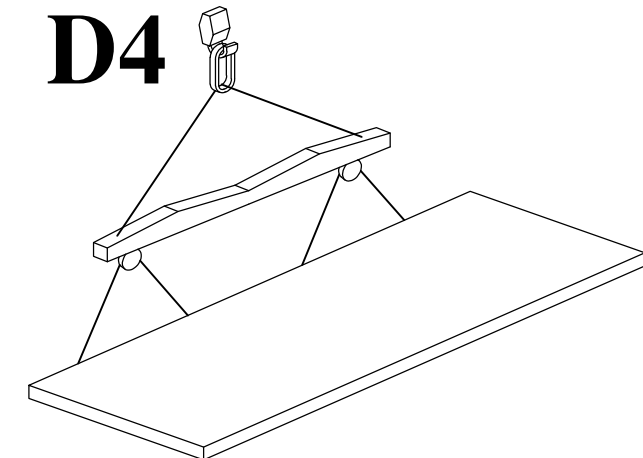

4 WAY EDGE WITH SPREADER

D5

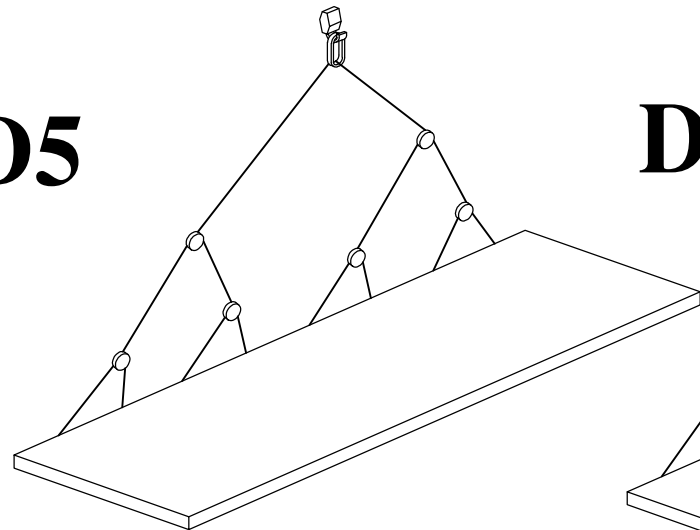

8 WAY EDGE

D6

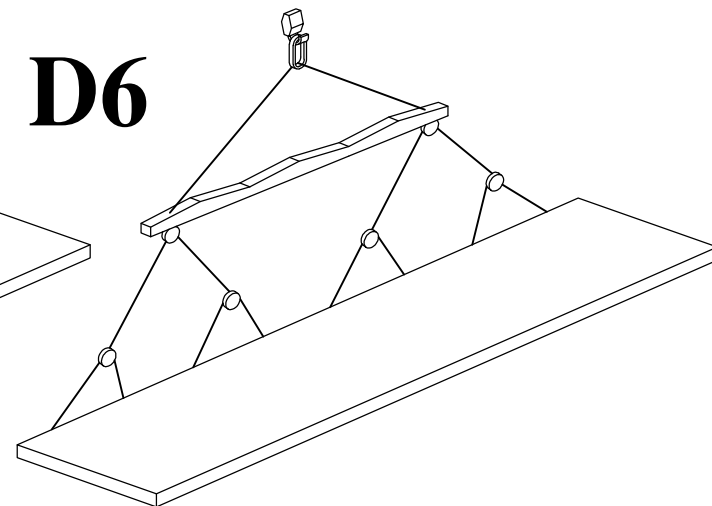

8 WAY EDGE WITH SPREADER

D7

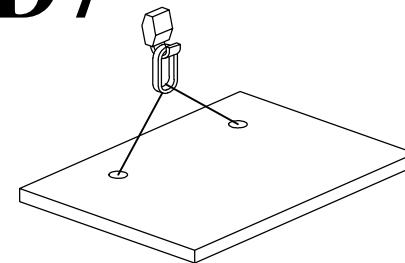

2 WAY FACE

D8

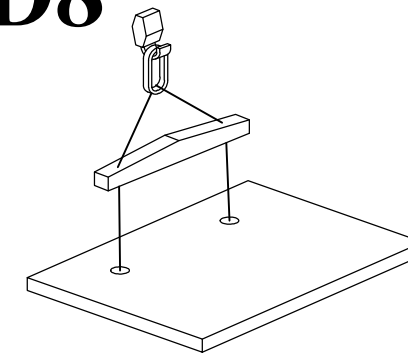

2 WAY FACE WITH SPREADER

D9

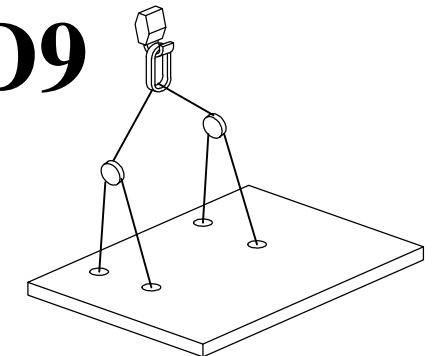

4 WAY FACE TILT LIFT

D10

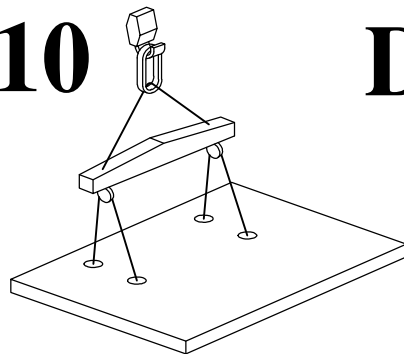

4 WAY FACE, TILT LIFT WITH SPREADER

D11

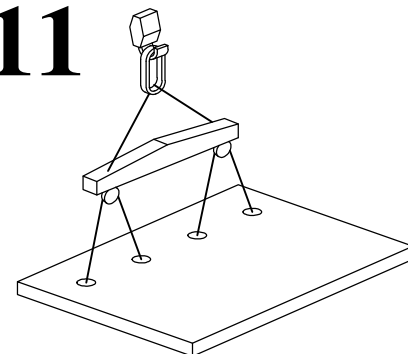

4 WAY FACE SINGLE ROW WITH SPREADER

D12

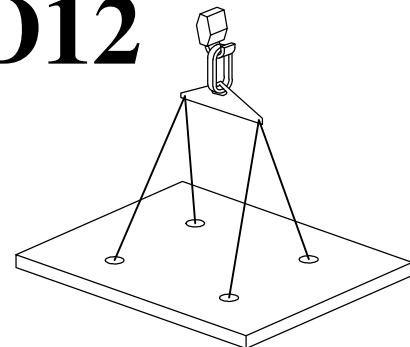

4 WAY FACE WITH LIFTING TRIANGLE FLAT LIFT **NO TOP PULLEYS**

D13

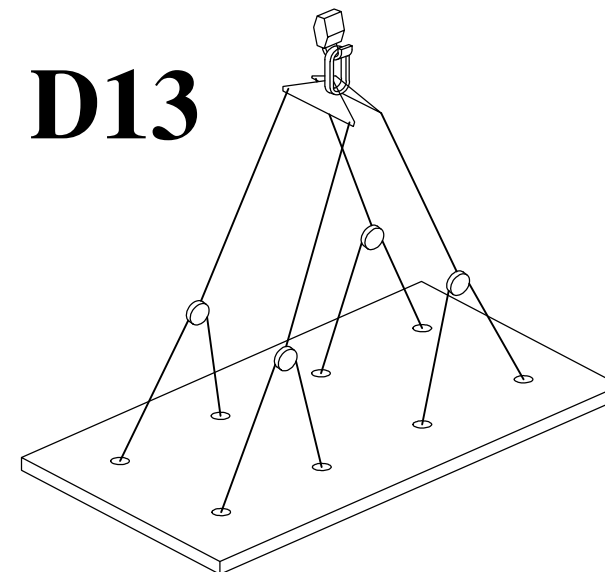

8 WAY FACE WITH LIFTING TRIANGLE FLAT LIFT **NO TOP PULLEYS**

D14

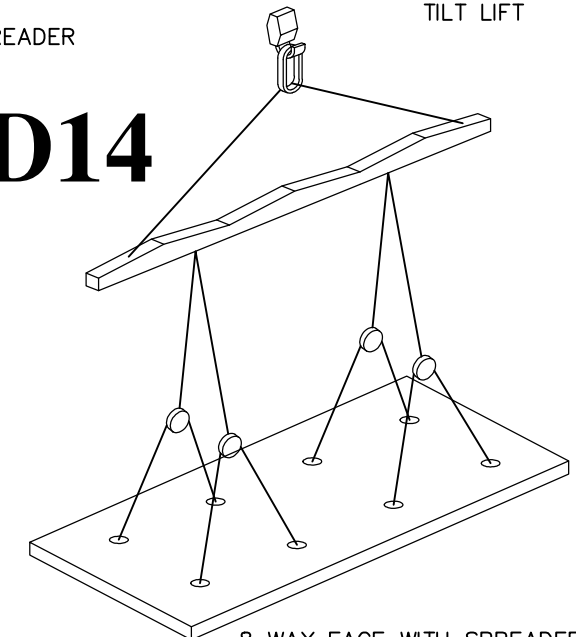

8 WAY FACE WITH SPREADER FLAT LIFT **NO TOP PULLEYS**

IF ANY CODE ON A DRAWING OR PANEL LABEL STATED AS "SPECIAL" OR "S" REFER TO THE SPECIFIC SHOP DRAWING FOR RIGGING / LIFTING ARRANGEMENT



PRECAST RIGGING CODE DEMOULDING OPTIONS

Revision:

B

Date:

31.07.2013

THIS INFORMATION IS PROVIDED AS A GUIDE ONLY, PLEASE REFER TO:

- ENGINEERS DRAWING DETAILS.
- APPROVED CODE OF PRACTICE FOR THE SAFE HANDLING, TRANSPORTATION AND ERECTION OF PRECAST CONCRETE.
- APPROVED CODE OF PRACTICE FOR LOAD-LIFTING RIGGING.
- LOAD LIFTING DESIGNERS DIAGRAMS, i.e. RAMSET, REID, ETC.

IMPORTANT

REFER TO THE PANEL SUPPLIER'S SHOP DRAWINGS FOR THE RIGGING ARRANGEMENTS TO BE USED FOR EACH OPERATION. ENSURE ALL LIFTING CLUTCHES AND OTHER EQUIPMENT IS COMPATIBLE WITH THE DEVICES CAST INTO THE PANEL BEFORE ATTACHING. ENSURE LOADS TO BE IMPOSED ON ALL DEVICES ARE WITHIN THE MANUFACTURER'S RECOMMENDATIONS.

D15

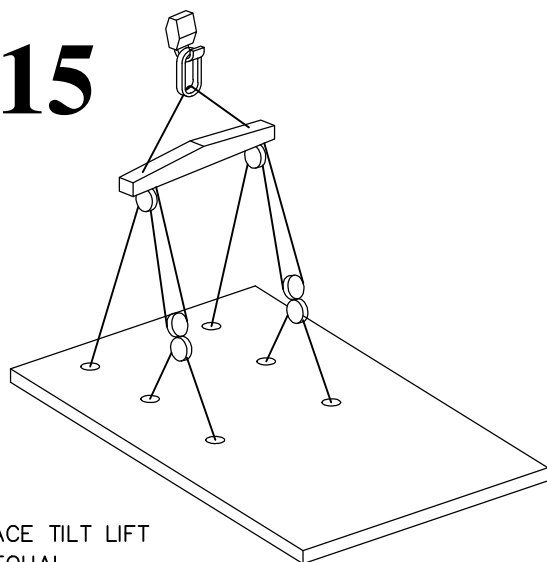

6 WAY FACE TILT LIFT
3 ROWS EQUAL
WITH SPREADER

D16

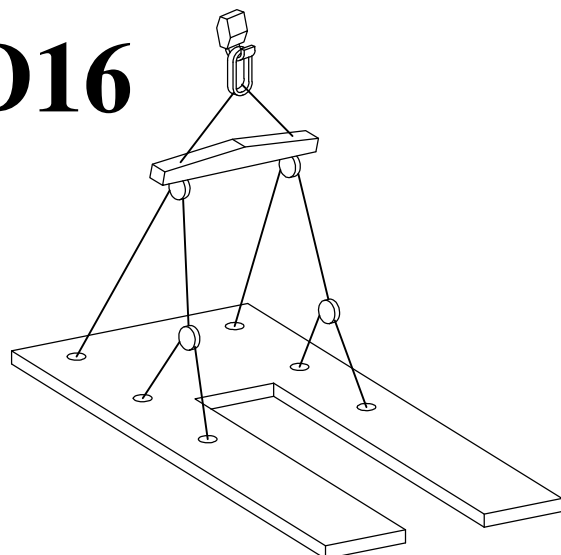

6 WAY FACE TILT LIFT 3 ROWS
TOP EYES WITH SPREADER
DOUBLE LOADING TOP EYES

D17

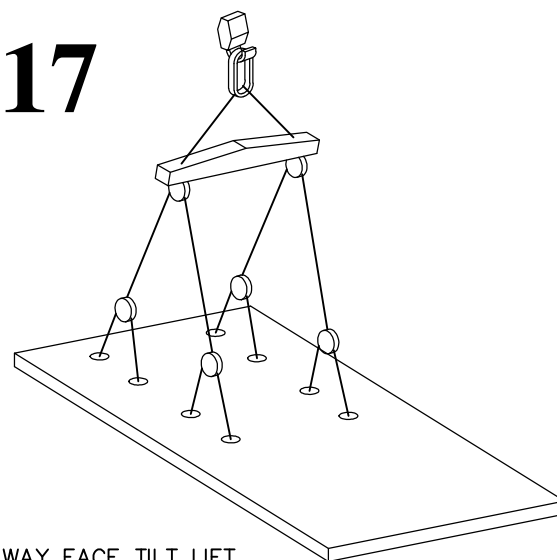

8 WAY FACE TILT LIFT
4 ROWS WITH SPREADER

D18

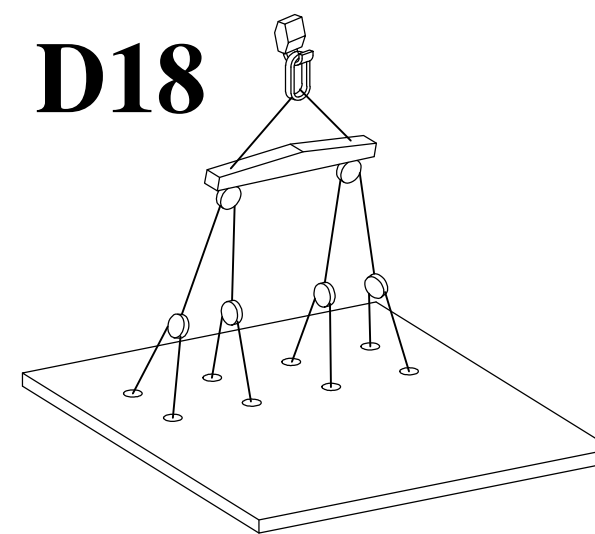

8 WAY FACE TILT LIFT
2 ROWS WITH SPREADER

D19

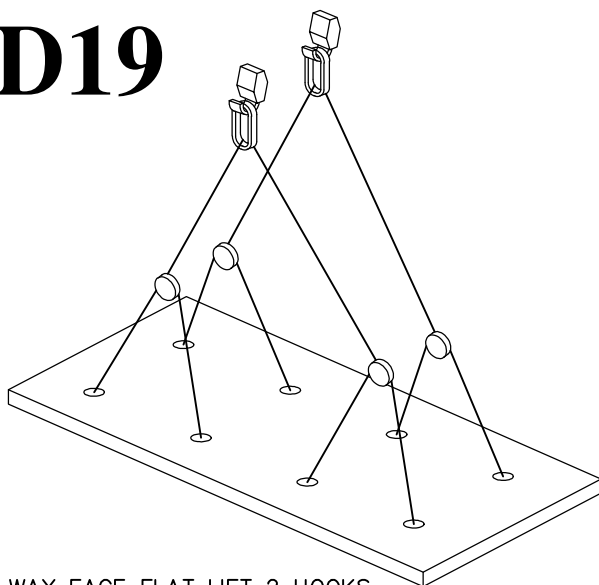

8 WAY FACE FLAT LIFT 2 HOOKS
(FOR ROTATION TO VERTICAL
OR VICE VERSA)

D20

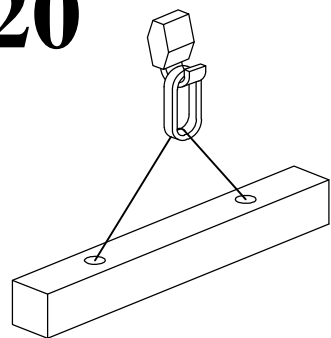

2 WAY FACE

D21

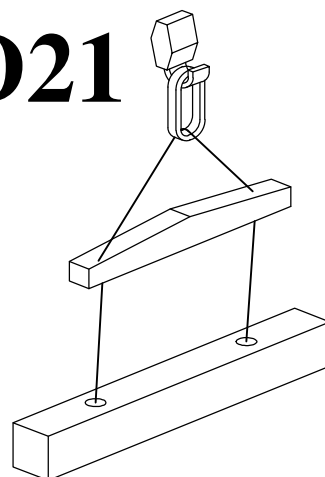

2 WAY FACE WITH SPREADER

D22

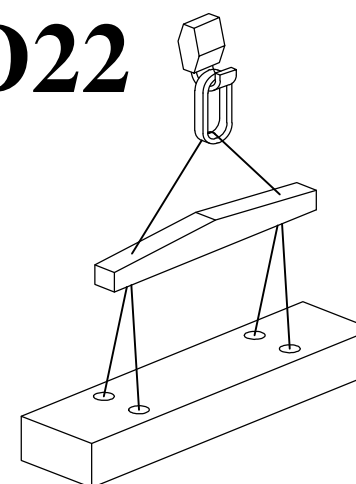

4 WAY FACE DOUBLE ROW
WITH SPREADER
NO TOP PULLEYS

D23

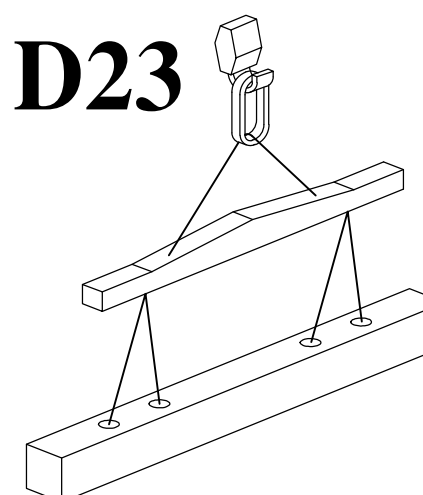

4 WAY FACE SINGLE ROW
WITH SPREADER
NO TOP PULLEYS

D24

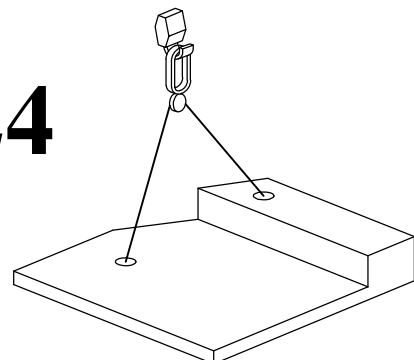

2 WAY FACE WITH PULLEY

D25

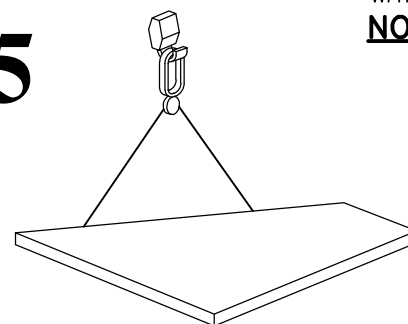

2 WAY EDGE WITH PULLEY

IF ANY CODE ON A DRAWING OR PANEL LABEL STATED AS "SPECIAL" OR "S" REFER TO THE SPECIFIC SHOP DRAWING FOR RIGGING / LIFTING ARRANGEMENT

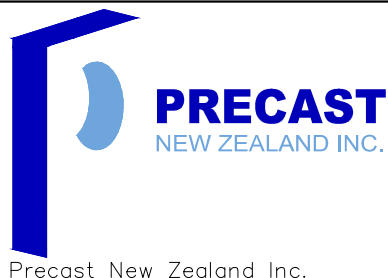

PRECAST RIGGING CODE DEMOULDING OPTIONS

Revision:

B

Date:

31.07.2013

THIS INFORMATION IS PROVIDED AS A GUIDE ONLY, PLEASE REFER TO:

- ENGINEERS DRAWING DETAILS.
- APPROVED CODE OF PRACTICE FOR THE SAFE HANDLING, TRANSPORTATION AND ERECTION OF PRECAST CONCRETE.
- APPROVED CODE OF PRACTICE FOR LOAD-LIFTING RIGGING.
- LOAD LIFTING DESIGNERS DIAGRAMS, i.e. RAMSET, REID, ETC.

IMPORTANT

REFER TO THE PANEL SUPPLIER'S SHOP DRAWINGS FOR THE RIGGING ARRANGEMENTS TO BE USED FOR EACH OPERATION. ENSURE ALL LIFTING CLUTCHES AND OTHER EQUIPMENT IS COMPATIBLE WITH THE DEVICES CAST INTO THE PANEL BEFORE ATTACHING. ENSURE LOADS TO BE IMPOSED ON ALL DEVICES ARE WITHIN THE MANUFACTURER'S RECOMMENDATIONS.

D26

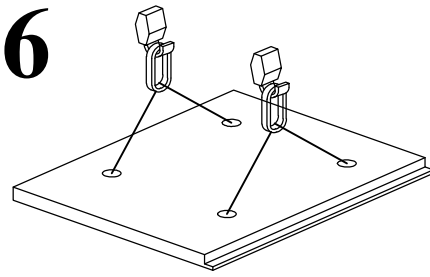

2X2 WAY FACE FLAT LIFT

D27

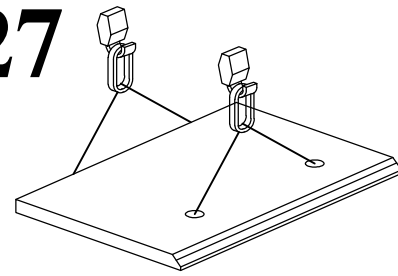

2 WAY FACE & 2 WAY EDGE FLAT LIFT

D28

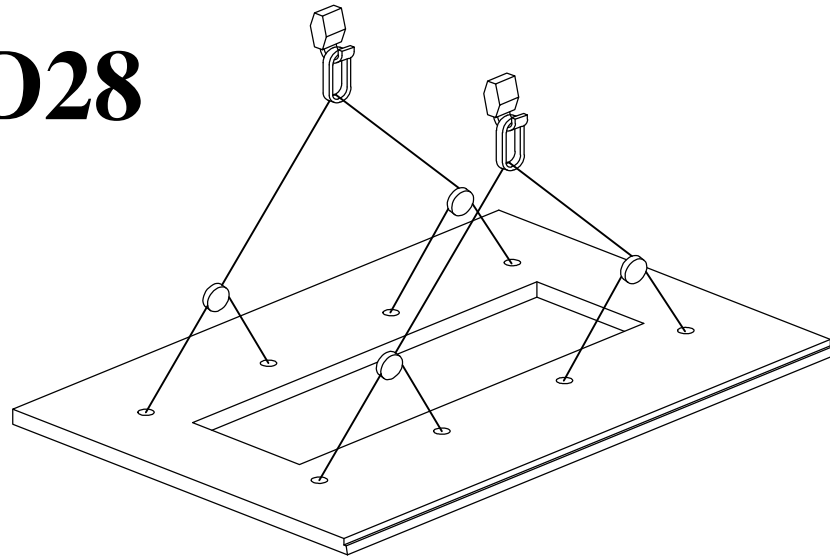

2X4 WAY FACE FLAT LIFT

D29

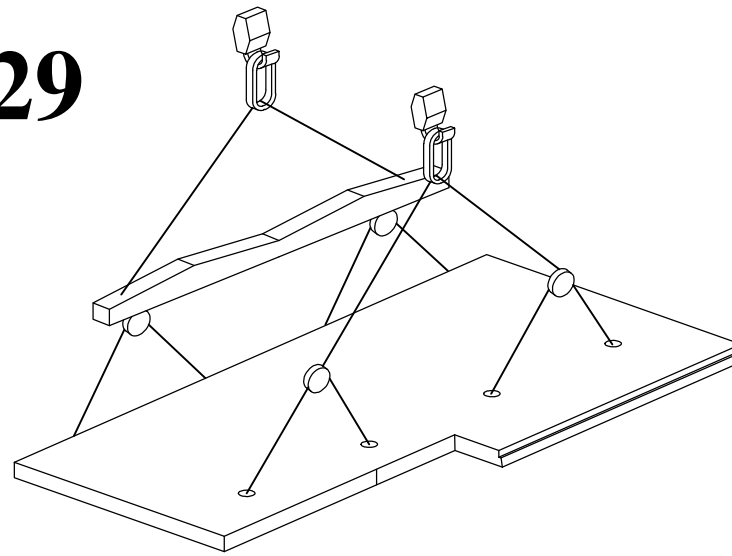

4 WAY EDGE WITH SPREADER & 4 WAY FACE FLAT LIFT (CAN TAIL OUT)

D30

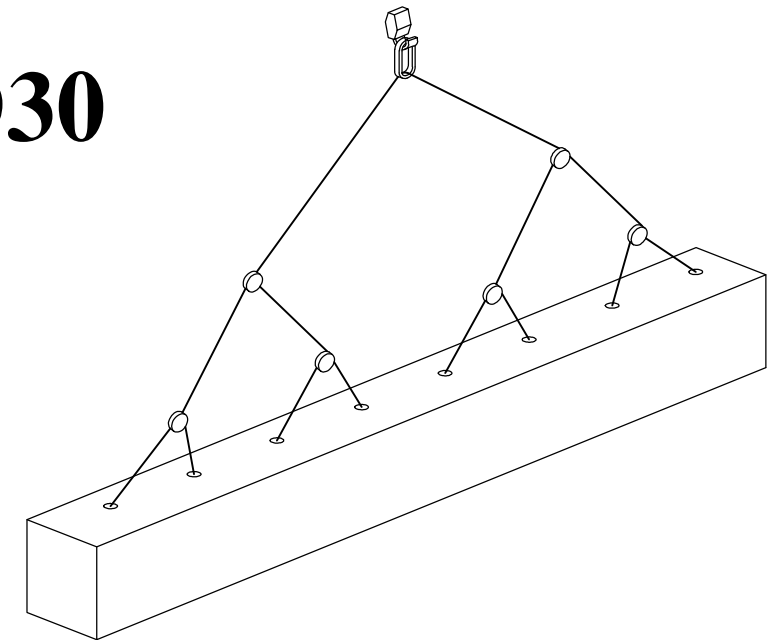

8 WAY FACE

D31

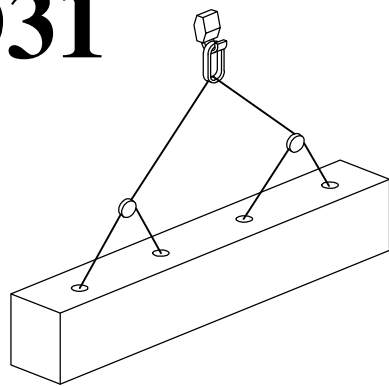

4 WAY FACE

D32

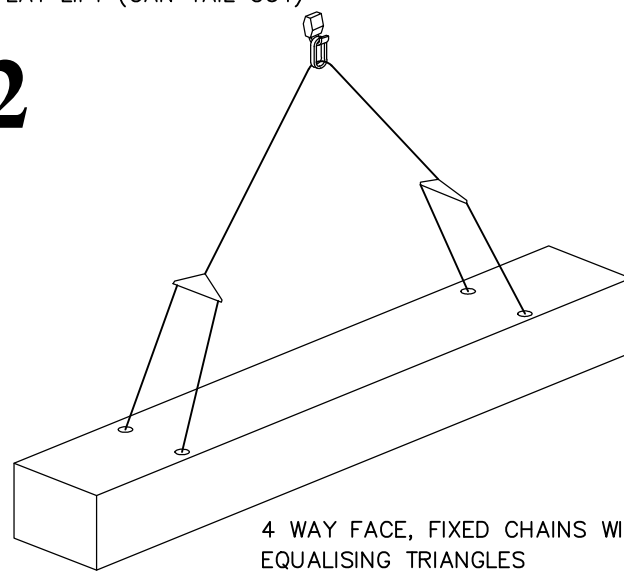

4 WAY FACE, FIXED CHAINS WITH EQUALISING TRIANGLES

IF ANY CODE ON A DRAWING OR PANEL LABEL STATED AS "SPECIAL" OR "S" REFER TO THE SPECIFIC SHOP DRAWING FOR RIGGING / LIFTING ARRANGEMENT



PRECAST RIGGING CODE DEMOULDING OPTIONS

Revision:

B

Date:

31.07.2013

THIS INFORMATION IS PROVIDED AS A GUIDE ONLY, PLEASE REFER TO:

- ENGINEERS DRAWING DETAILS.
- APPROVED CODE OF PRACTICE FOR THE SAFE HANDLING, TRANSPORTATION AND ERECTION OF PRECAST CONCRETE.
- APPROVED CODE OF PRACTICE FOR LOAD-LIFTING RIGGING.
- LOAD LIFTING DESIGNERS DIAGRAMS, i.e. RAMSET, REID, ETC.

IMPORTANT

REFER TO THE PANEL SUPPLIER'S SHOP DRAWINGS FOR THE RIGGING ARRANGEMENTS TO BE USED FOR EACH OPERATION. ENSURE ALL LIFTING CLUTCHES AND OTHER EQUIPMENT IS COMPATIBLE WITH THE DEVICES CAST INTO THE PANEL BEFORE ATTACHING. ENSURE LOADS TO BE IMPOSED ON ALL DEVICES ARE WITHIN THE MANUFACTURER'S RECOMMENDATIONS.

NOTE:
F – DENOTES FACE LIFT

P1

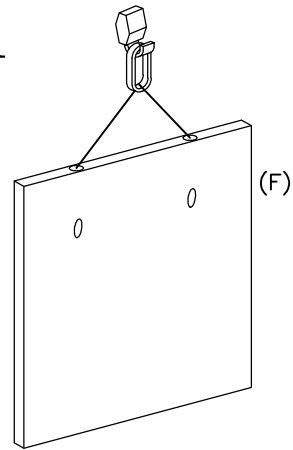

2 WAY EDGE
OR
2 WAY FACE **P1-F**

P2

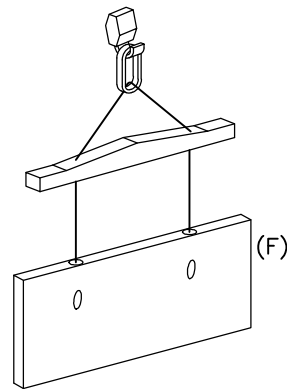

2 WAY EDGE WITH SPREADER
OR
2 WAY FACE **P2-F**

P3

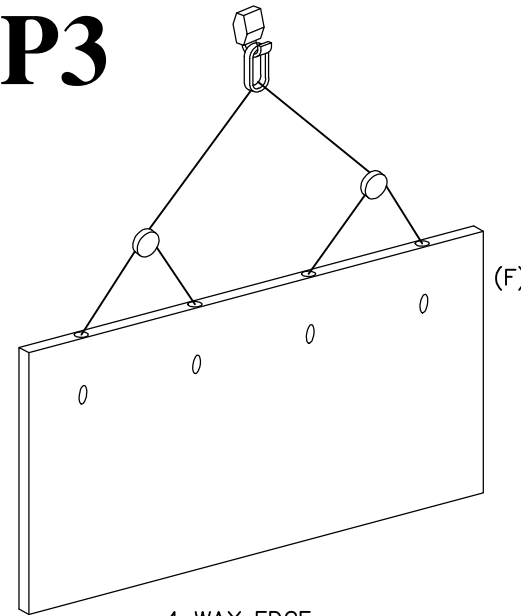

4 WAY EDGE
OR
4 WAY FACE **P3-F**

P4

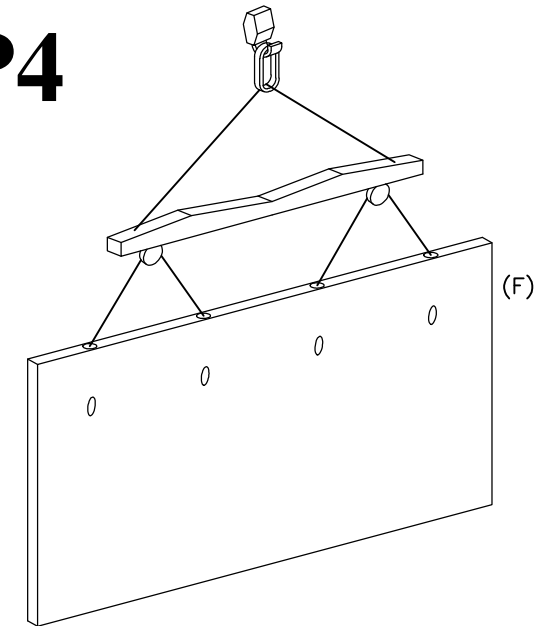

4 WAY EDGE WITH SPREADER AND TOP PULLEYS
OR
4 WAY FACE **P4-F**

P5

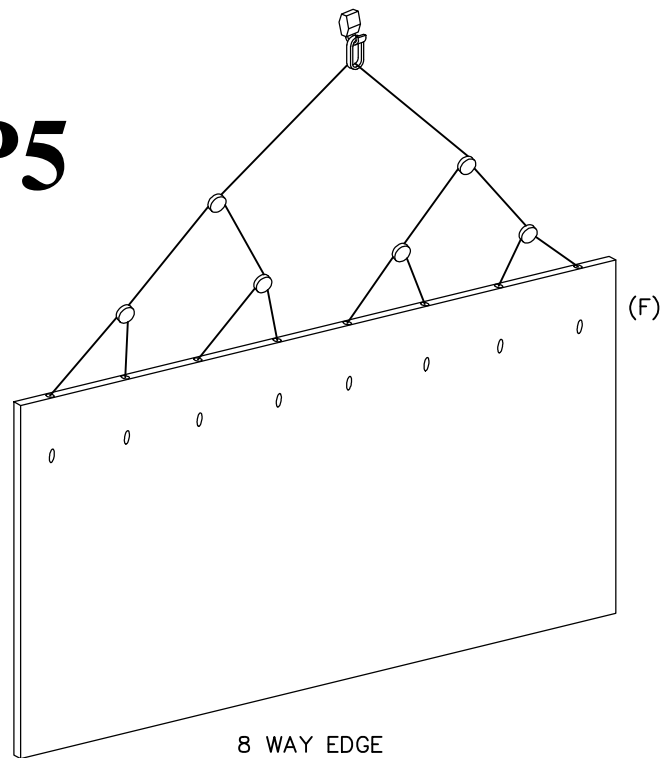

8 WAY EDGE
OR
8 WAY FACE **P5-F**

P6

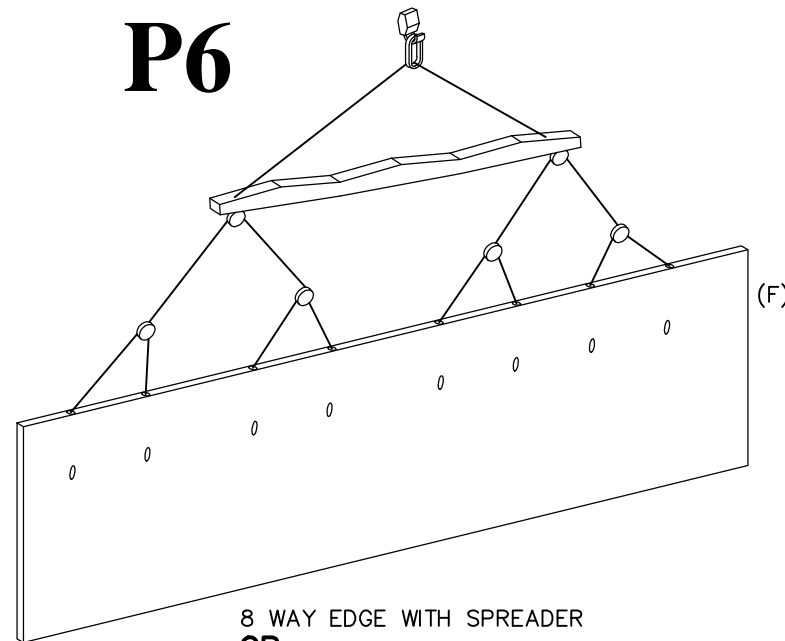

8 WAY EDGE WITH SPREADER
OR
8 WAY FACE **P6-F**

P7

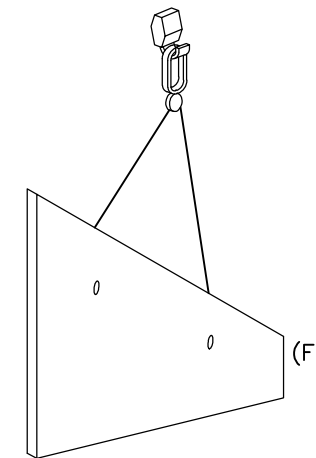

2 WAY EDGE WITH TOP PULLEY
OR
2 WAY FACE **P7-F**

IF ANY CODE ON A DRAWING OR PANEL LABEL STATED AS "SPECIAL" OR "S" REFER TO THE SPECIFIC SHOP DRAWING FOR RIGGING / LIFTING ARRANGEMENT

PRECAST RIGGING CODE PLACEMENT OPTIONS

Revision:

B

Date:

31.07.2013

THIS INFORMATION IS PROVIDED AS A GUIDE ONLY, PLEASE REFER TO:

- ENGINEERS DRAWING DETAILS.
- APPROVED CODE OF PRACTICE FOR THE SAFE HANDLING, TRANSPORTATION AND ERECTION OF PRECAST CONCRETE.
- APPROVED CODE OF PRACTICE FOR LOAD-LIFTING RIGGING.
- LOAD LIFTING DESIGNERS DIAGRAMS, i.e. RAMSET, REID, ETC.

IMPORTANT

REFER TO THE PANEL SUPPLIER'S SHOP DRAWINGS FOR THE RIGGING ARRANGEMENTS TO BE USED FOR EACH OPERATION. ENSURE ALL LIFTING CLUTCHES AND OTHER EQUIPMENT IS COMPATIBLE WITH THE DEVICES CAST INTO THE PANEL BEFORE ATTACHING. ENSURE LOADS TO BE IMPOSED ON ALL DEVICES ARE WITHIN THE MANUFACTURER'S RECOMMENDATIONS.

P8

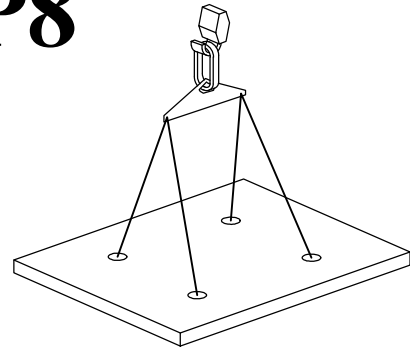

4 WAY FACE EQUAL LOAD

P9

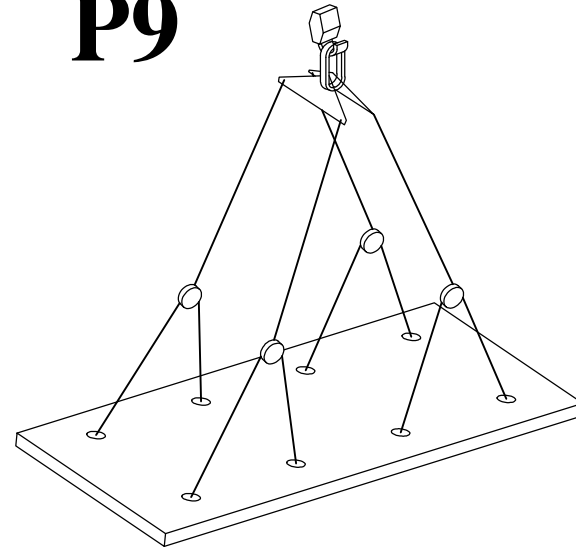

8 WAY FACE EQUAL LOAD
NO TOP PULLEYS

P10

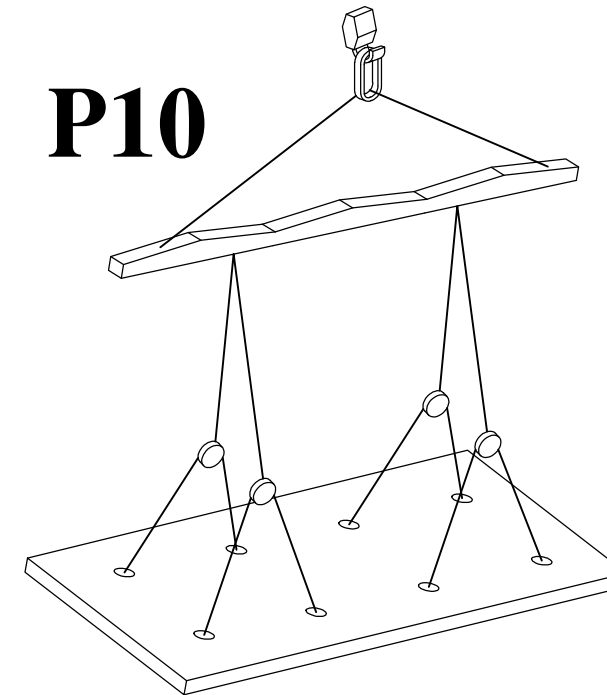

8 WAY FACE EQUAL LOAD WITH SPREADER
NO TOP PULLEYS

P11

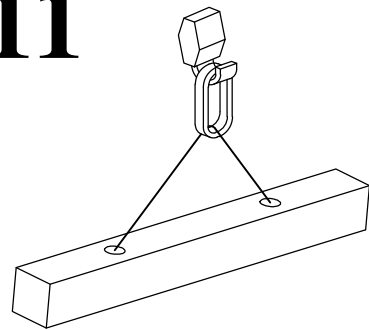

2 WAY FACE

P12

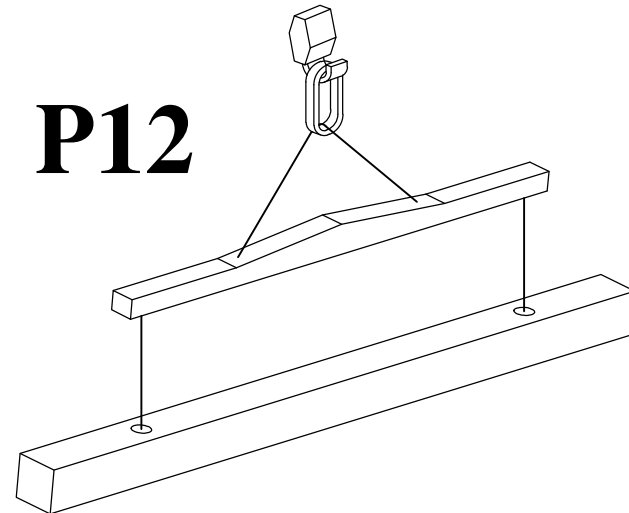

2 WAY FACE WITH SPREADER

P13

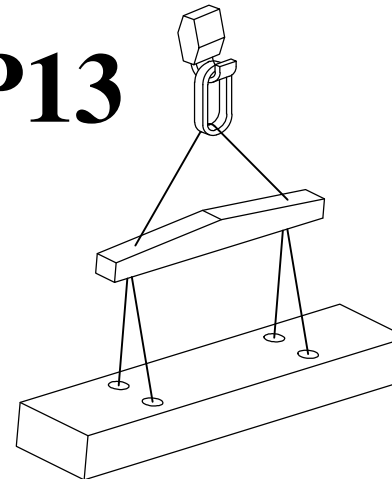

4 WAY FACE DOUBLE ROW
WITH SPREADER
NO TOP PULLEYS

P14

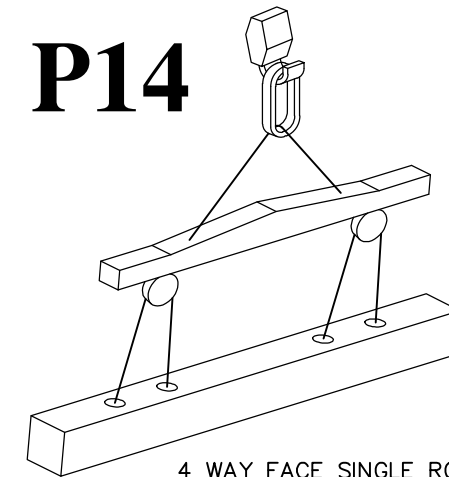

4 WAY FACE SINGLE ROW
WITH SPREADER
AND TOP PULLEYS

IF ANY CODE ON A DRAWING OR PANEL LABEL STATED AS "SPECIAL" OR "S" REFER TO THE SPECIFIC SHOP DRAWING FOR RIGGING / LIFTING ARRANGEMENT



PRECAST RIGGING CODE PLACEMENT OPTIONS

Revision:

B

Date:

31.07.2013

THIS INFORMATION IS PROVIDED AS A GUIDE ONLY, PLEASE REFER TO:

- ENGINEERS DRAWING DETAILS.
- APPROVED CODE OF PRACTICE FOR THE SAFE HANDLING, TRANSPORTATION AND ERECTION OF PRECAST CONCRETE.
- APPROVED CODE OF PRACTICE FOR LOAD-LIFTING RIGGING.
- LOAD LIFTING DESIGNERS DIAGRAMS, i.e. RAMSET, REID, ETC.

IMPORTANT

REFER TO THE PANEL SUPPLIER'S SHOP DRAWINGS FOR THE RIGGING ARRANGEMENTS TO BE USED FOR EACH OPERATION. ENSURE ALL LIFTING CLUTCHES AND OTHER EQUIPMENT IS COMPATIBLE WITH THE DEVICES CAST INTO THE PANEL BEFORE ATTACHING. ENSURE LOADS TO BE IMPOSED ON ALL DEVICES ARE WITHIN THE MANUFACTURER'S RECOMMENDATIONS.

P15

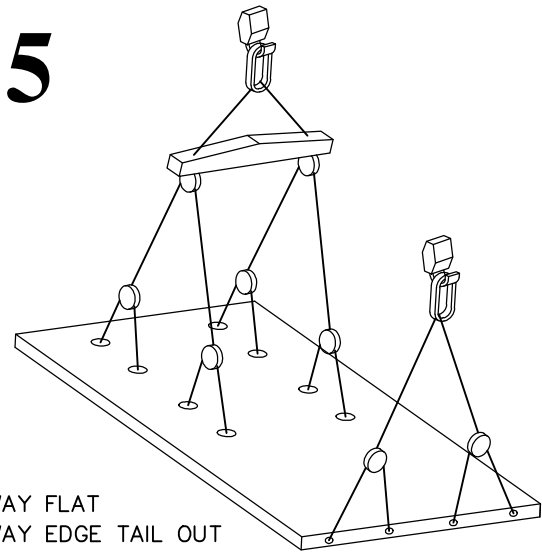

8 WAY FLAT
4 WAY EDGE TAIL OUT

P16

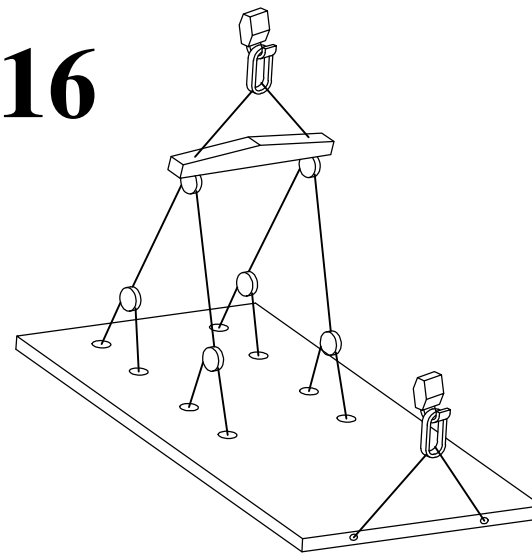

8 WAY FACE
2 WAY EDGE TAIL OUT

P17

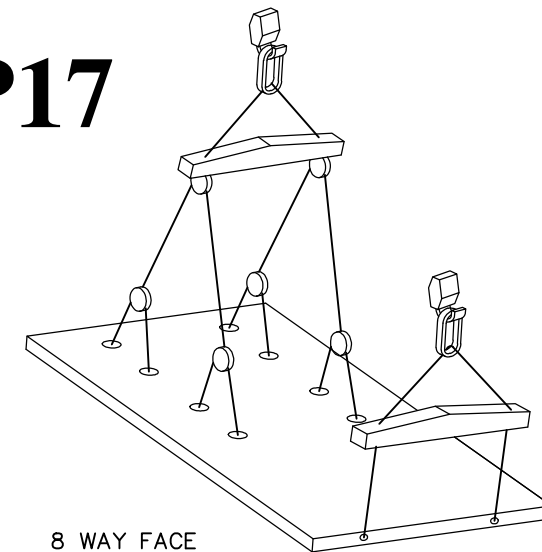

8 WAY FACE
2 WAY EDGE TAIL OUT WITH SPREADER

P18

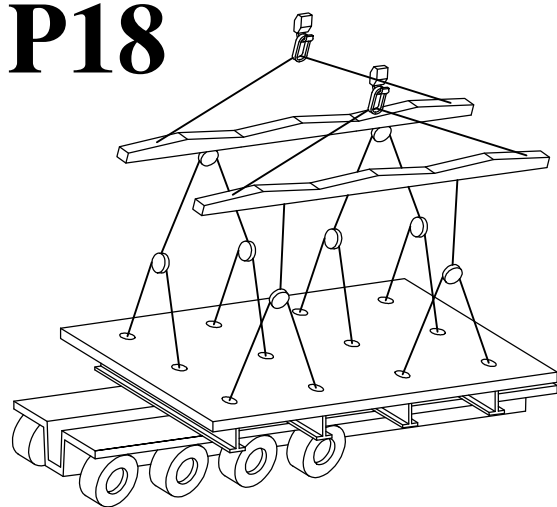

8 WAY FACE
4 WAY FACE TAIL OUT

P19

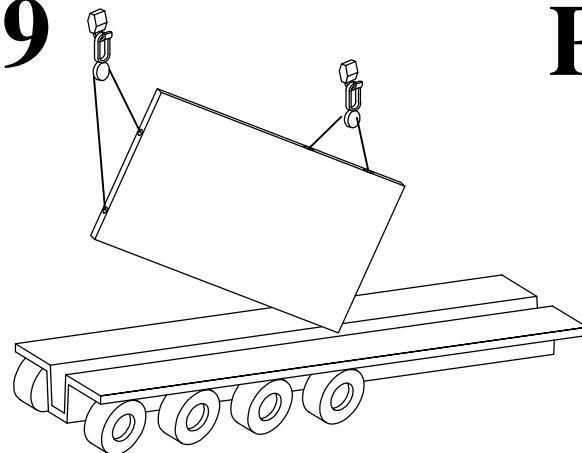

2 WAY EDGE + 2 WAY EDGE TAIL OUT

P20

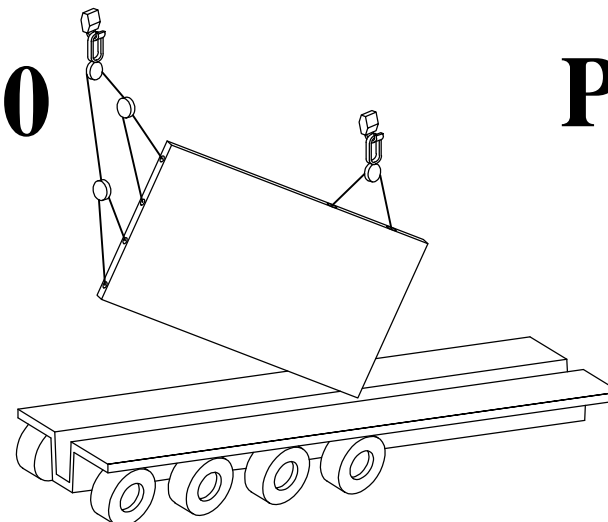

4 WAY EDGE + 2 WAY EDGE TAIL OUT

P21

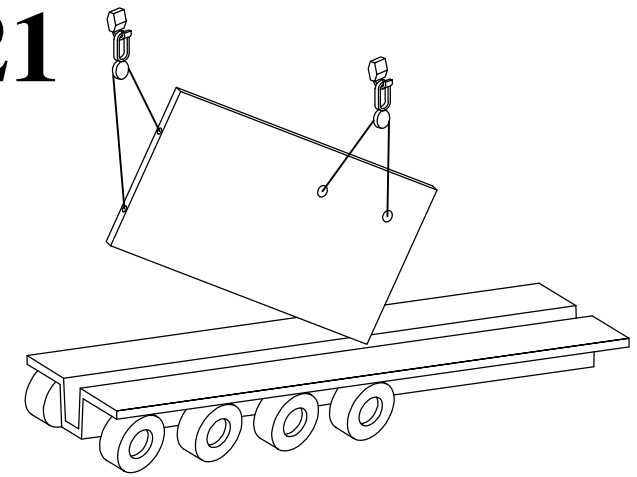

2 WAY EDGE + 2 WAY FACE TAIL OUT

IF ANY CODE ON A DRAWING OR PANEL LABEL STATED AS "SPECIAL" OR "S" REFER TO THE SPECIFIC SHOP DRAWING FOR RIGGING / LIFTING ARRANGEMENT



PRECAST RIGGING CODE PLACEMENT OPTIONS

Revision:

B

Date:

31.07.2013

THIS INFORMATION IS PROVIDED AS A GUIDE ONLY, PLEASE REFER TO:

- ENGINEERS DRAWING DETAILS.
- APPROVED CODE OF PRACTICE FOR THE SAFE HANDLING, TRANSPORTATION AND ERECTION OF PRECAST CONCRETE.
- APPROVED CODE OF PRACTICE FOR LOAD-LIFTING RIGGING.
- LOAD LIFTING DESIGNERS DIAGRAMS, i.e. RAMSET, REID, ETC.

IMPORTANT

REFER TO THE PANEL SUPPLIER'S SHOP DRAWINGS FOR THE RIGGING ARRANGEMENTS TO BE USED FOR EACH OPERATION. ENSURE ALL LIFTING CLUTCHES AND OTHER EQUIPMENT IS COMPATIBLE WITH THE DEVICES CAST INTO THE PANEL BEFORE ATTACHING. ENSURE LOADS TO BE IMPOSED ON ALL DEVICES ARE WITHIN THE MANUFACTURER'S RECOMMENDATIONS.

P22

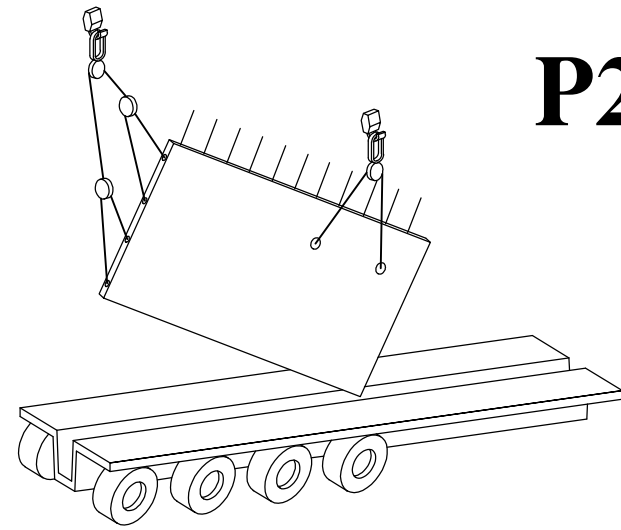

4 WAY EDGE +2 WAY FACE TAIL OUT

P23

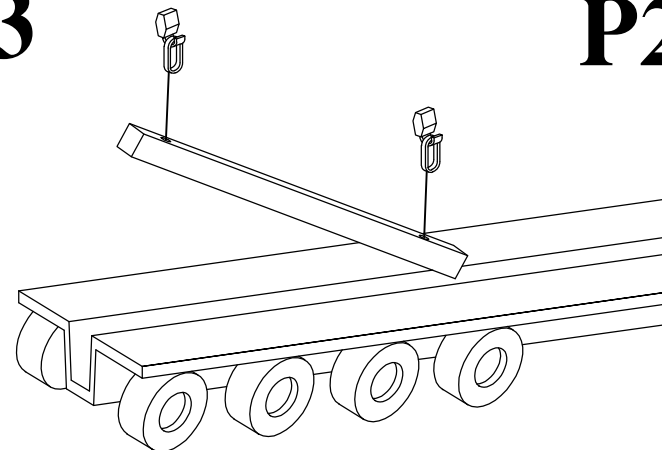

1 WAY FACE +1 WAY FACE TAIL OUT

P24

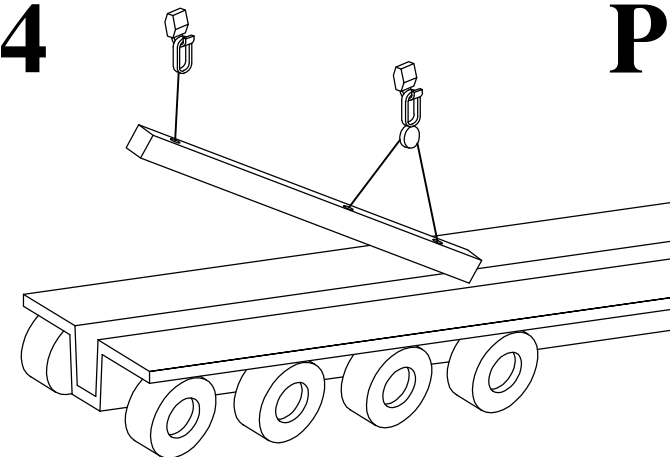

1 WAY FACE + 2 WAY FACE TAIL OUT

P25

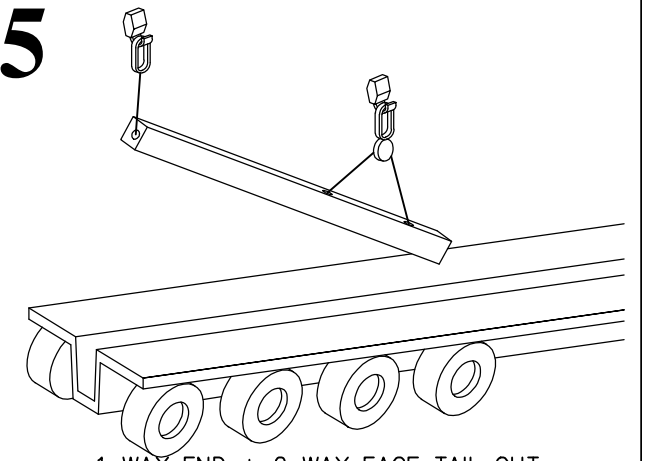

1 WAY END + 2 WAY FACE TAIL OUT

P26

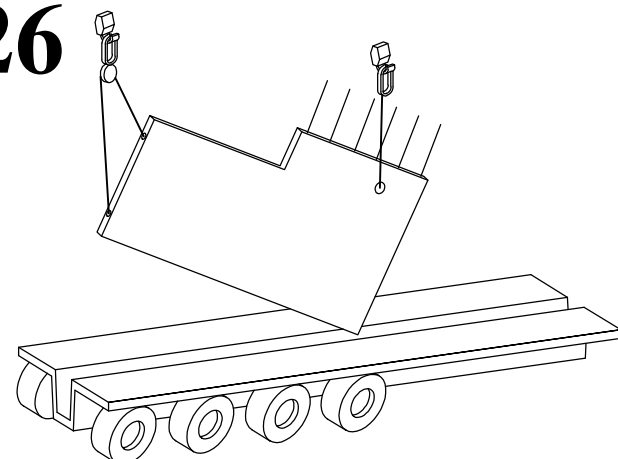

2 WAY EDGE +1 WAY FACE TAIL OUT

P27

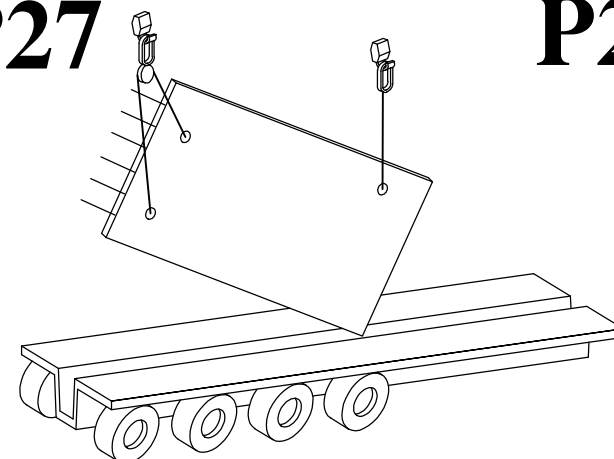

2 WAY FACE +1 WAY FACE TAIL OUT

P28

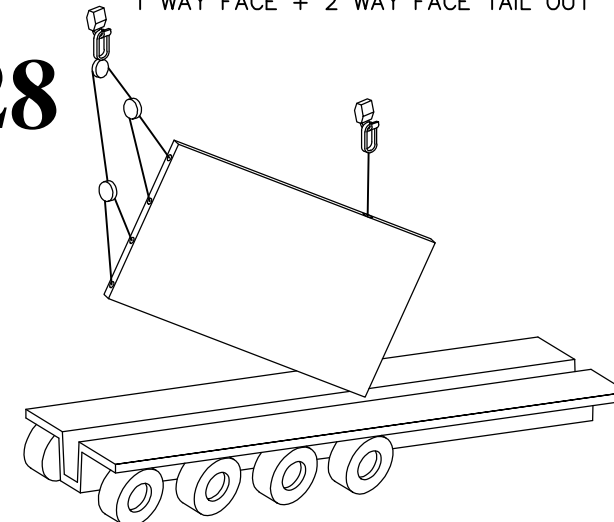

4 WAY EDGE +1 WAY EDGE TAIL OUT

P29

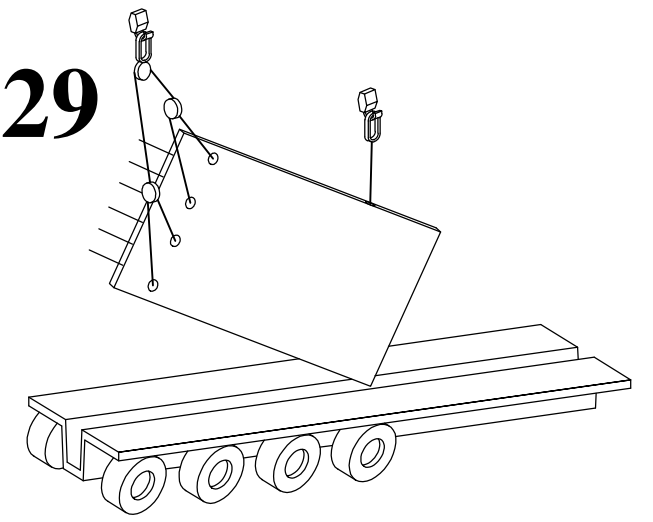

4 WAY FACE +1 WAY EDGE TAIL OUT

P30

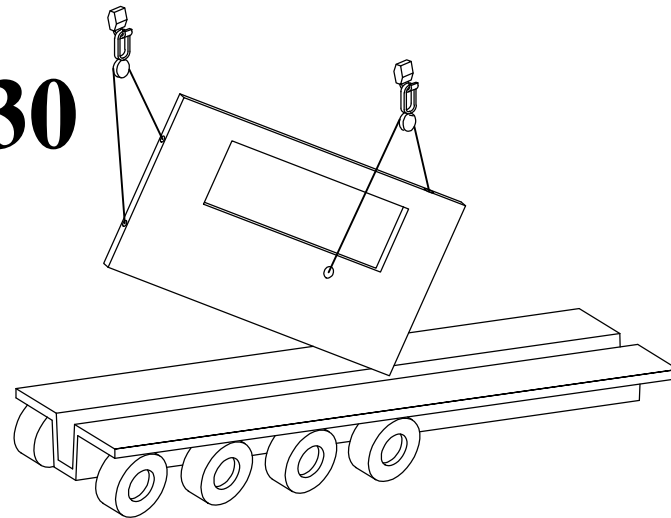

2 WAY EDGE +2 WAY FACE/EDGE TAIL OUT

P31

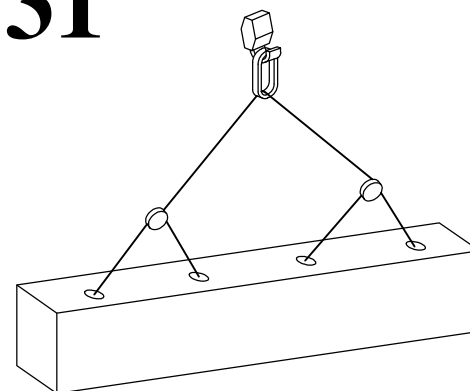

4 WAY FACE

P32

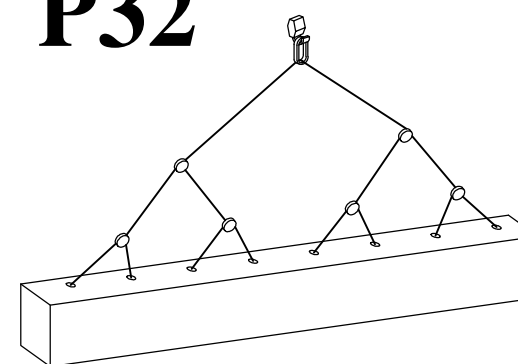

8 WAY FACE

P33

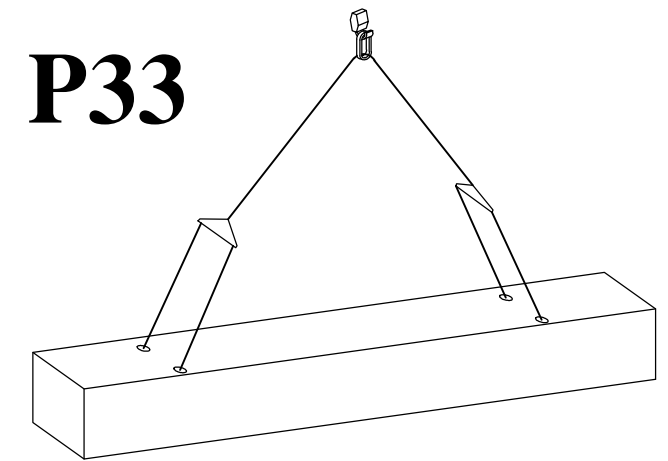

4 WAY FACE, FIXED CHAINS WITH EQUALISING TRIANGLES

IF ANY CODE ON A DRAWING OR PANEL LABEL STATED AS "SPECIAL" OR "S" REFER TO THE SPECIFIC SHOP DRAWING FOR RIGGING / LIFTING ARRANGEMENT



PRECAST RIGGING CODE PLACEMENT OPTIONS

Revision:

B

Date:

31.07.2013

THIS INFORMATION IS PROVIDED AS A GUIDE ONLY, PLEASE REFER TO:

- ENGINEERS DRAWING DETAILS.
- APPROVED CODE OF PRACTICE FOR THE SAFE HANDLING, TRANSPORTATION AND ERECTION OF PRECAST CONCRETE.
- APPROVED CODE OF PRACTICE FOR LOAD-LIFTING RIGGING.
- LOAD LIFTING DESIGNERS DIAGRAMS, i.e. RAMSET, REID, ETC.

IMPORTANT

REFER TO THE PANEL SUPPLIER'S SHOP DRAWINGS FOR THE RIGGING ARRANGEMENTS TO BE USED FOR EACH OPERATION. ENSURE ALL LIFTING CLUTCHES AND OTHER EQUIPMENT IS COMPATIBLE WITH THE DEVICES CAST INTO THE PANEL BEFORE ATTACHING. ENSURE LOADS TO BE IMPOSED ON ALL DEVICES ARE WITHIN THE MANUFACTURER'S RECOMMENDATIONS.

T1

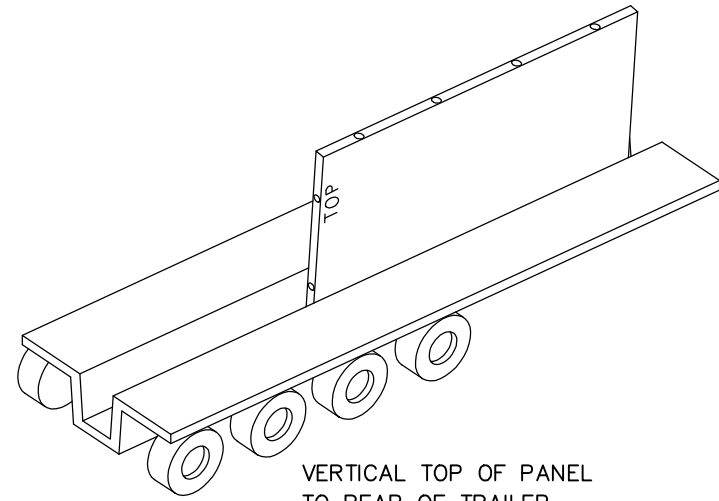

VERTICAL TOP OF PANEL TO REAR OF TRAILER

T2

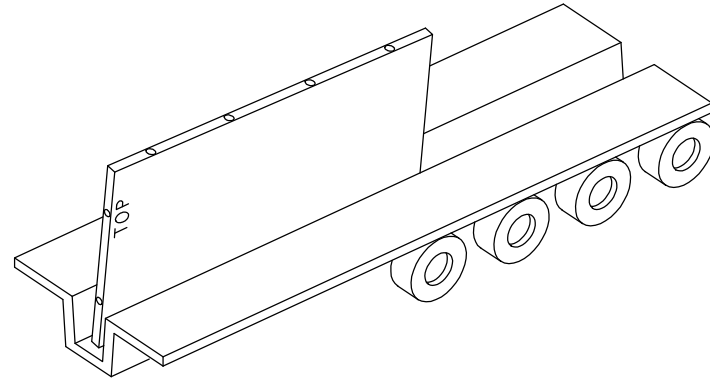

VERTICAL TOP OF PANEL TO FRONT OF TRAILER

T3

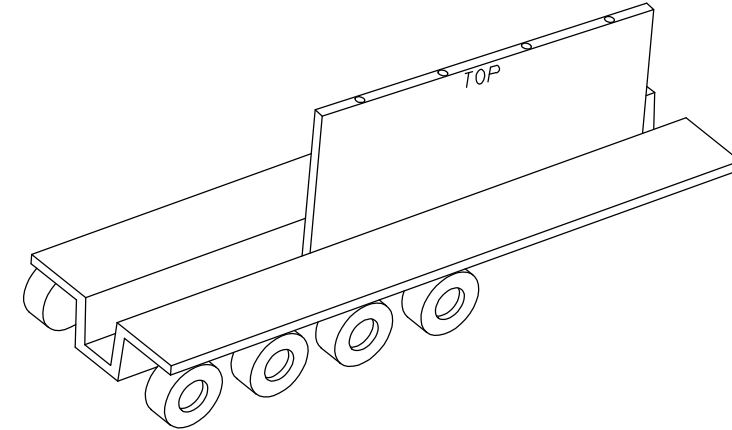

VERTICAL TOP OF PANEL TO TOP OF TRAILER

T4

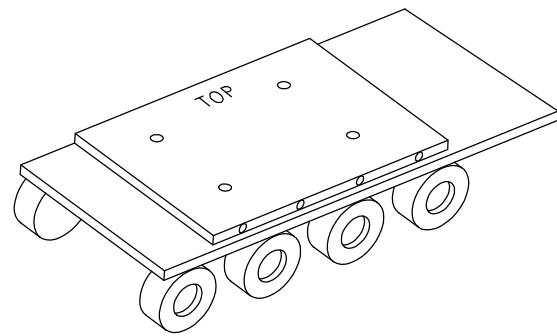

FLAT LIFT, TOP OF PANEL TO SIDE OF TRAILER

T5

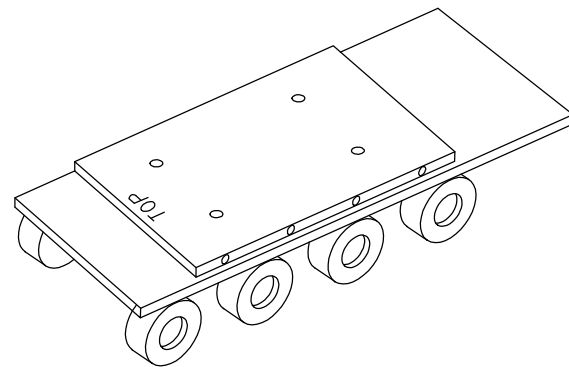

FLAT LIFT, TOP OF PANEL TO REAR OF TRAILER

T6

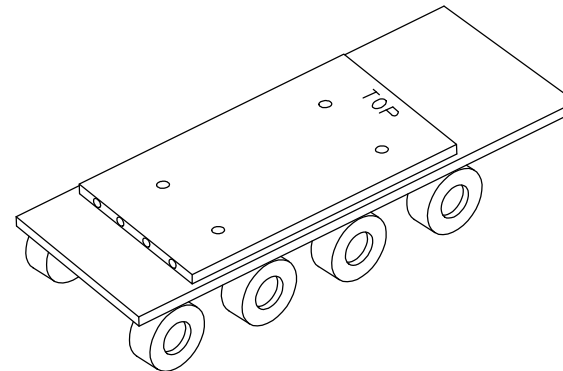

FLAT LIFT, TOP OF PANEL TO FRONT OF TRAILER

T7

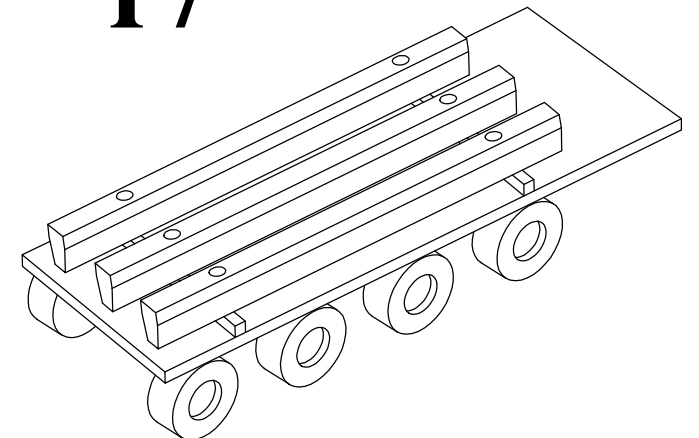

TRANSPORT ON FLAT DECK DUNNAGE UNDER LIFTING POINTS (UNISPAN, INTERSPAN, BEAMS AND OTHERS SIMILAR ITEMS)

IF ANY CODE ON A DRAWING OR PANEL LABEL STATED AS "SPECIAL" OR "S" REFER TO THE SPECIFIC SHOP DRAWING FOR RIGGING / LIFTING ARRANGEMENT



PRECAST RIGGING CODE TRANSPORT OPTIONS

Revision:

B

Date:

31.07.2013

THIS INFORMATION IS PROVIDED AS A GUIDE ONLY, PLEASE REFER TO:

- ENGINEERS DRAWING DETAILS.
- APPROVED CODE OF PRACTICE FOR THE SAFE HANDLING, TRANSPORTATION AND ERECTION OF PRECAST CONCRETE.
- APPROVED CODE OF PRACTICE FOR LOAD-LIFTING RIGGING.
- LOAD LIFTING DESIGNERS DIAGRAMS, i.e. RAMSET, REID, ETC.

IMPORTANT

REFER TO THE PANEL SUPPLIER'S SHOP DRAWINGS FOR THE RIGGING ARRANGEMENTS TO BE USED FOR EACH OPERATION. ENSURE ALL LIFTING CLUTCHES AND OTHER EQUIPMENT IS COMPATIBLE WITH THE DEVICES CAST INTO THE PANEL BEFORE ATTACHING. ENSURE LOADS TO BE IMPOSED ON ALL DEVICES ARE WITHIN THE MANUFACTURER'S RECOMMENDATIONS.